

IPC DRILL 450 B

Conformity 

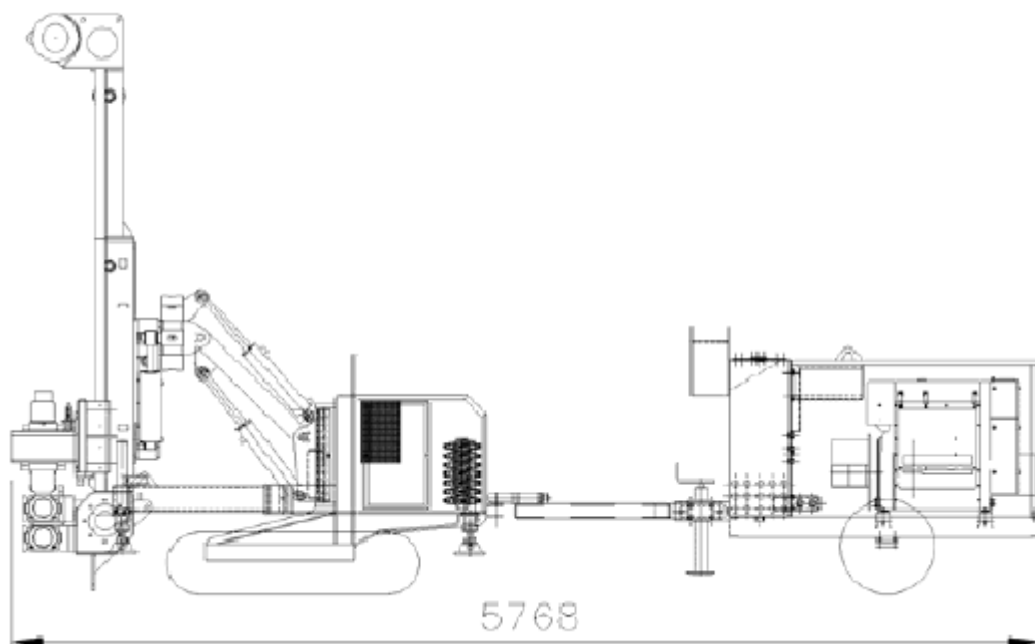

The DRILL 450 unit is the powerful medium size rig suitable for multi-directional drilling operations. The machine is designed for soil consolidation applications, micro-piling operations, anchors, core drilling and jet grouting.



UNDERCARRIAGE	Max. width	1164 mm
	Pitch	1404 mm
	Track shoes width	230 mm
	Max. speed	2,8 km/h
	Ground bearing pressure	0,42 daN/cm ²
	DIESEL ENGINE	HATZ 3L41C Installed power @ 2300 r.p.m.
HATZ 4L41C Installed power @ 2300 r.p.m.		47 kW
STANDARD ROTARY	Max. torque	735 daNm
	Max. rev.	120 r.p.m.
	Gears	n° 2
CLAMP/BREAKER	Max. opening	205 mm
	Clamping force	15900 daN
	Breaking torque	1950 daNm
MAST	Max. Retraction force	4500 daN
	Max. Pull force	2500 daN
	Max. speed	26 m/1'
	Max. Length (1500 mm)	3000 mm
WINCH	Max. pull	1000 daN
	Max. speed	43 m/1'
WEIGHT	2700 kg	

